

MODEL 538

OSCILLOSCOPE

INSTRUCTION MANUAL

KIKUSUI ELECTRONICS CORP.

\* This unit is to be used by AC..... V 50/60 Hz.

\* Contents of manual on input voltages are to be based on a standard voltage of AC 100V 50/60 Hz.

\* Please note beforehand that there is possibility of any difference between the unit itself and the circuit or a part of explanation on manual.

\* AC plug will differ with countries. In case of no plugs, please fix your suitable plugs at your side.

## TABLE OF CONTENTS

1.	GENERAL .....	1
2.	SPECIFICATIONS .....	2
3.	EXPLANATION OF PANEL .....	4
4.	OPERATING PROCEDURE .....	8
	4 - 1 First Operation .....	8
	4 - 2 Application .....	9
5.	CAUTION ON OPERATION .....	12
	5 - 1 Supply Line Voltage .....	12
	5 - 2 Fuse .....	12
	5 - 3 Ambient Temperature .....	12
	5 - 4 Maximum Input Voltage .....	12
	5 - 5 Life of the CRT .....	13
	5 - 6 Maximum Input Voltage to EXT HORIZ IN Terminal without Distortion of Waveform .....	13
6.	MAINTENANCE AND CALIBRATION .....	14
	6 - 1 Case Removal .....	14
	6 - 2 Change of Supply Line Voltage .....	14
	6 - 3 Exchange of the Fuse .....	14
	6 - 4 Adjustment of DC Balance .....	14
	6 - 5 Phase Compensation for VERT GAIN switch .....	15
	6 - 6 Adjustment of High Frequency Response Compensation of the Vertical Amplifier .....	15
	6 - 7 Adjustment of Horizontal DC Balance .....	16
	6 - 8 Adjustment of Trace Alignment .....	16

528. 9500

## 1. GENERAL

The Model 538 is a compact, highly reliable, universal purpose oscilloscope which employs compact 75mm round screen cathode-ray tube, solid-state electronics, and unique light weight metallic alloy housing

The vertical system provides a sensitivity of 10 mV/div or over and a frequency bandwidth of DC~1.5 MHz. It has a direct CRT input terminal.

The time axis circuit provides sweep frequencies of 10 Hz ~ 100 kHz sweep, and synchronizing with INT " - " only. When this circuit is switched over to the external sweep mode, it provides a deflection sensitivity of 250 mV/div or over and a frequency band of DC ~ 500 kHz. The external signal is applicable through a front panel terminal. This mode can be employed for X - Y operation of the oscilloscope, providing a high operation flexibility.

Since solid-state electronics is employed throughout the circuits, the oscilloscope can start operating only in less than 20 seconds after its power is turned on. Since heat-generating components and hence the instrument wattage are minimized, the drift is very small and an improved operation reliability is attained.

## 2. SPECIFICATIONS

### VERTICAL DEFLECTION SYSTEM

Characteristic	Specification	Remarks
Sensitivity	10 mV/DIV or over	1 DIV 6 mm
Frequency bandwidth	AC : 2 Hz ~ 1.5 MHz DC : DC ~ 1.5 MHz	within - 3 dB
Attenuator	1/1, 1/10, 1/100 and GND	
Attenuator accuracy	within $\pm 3\%$	
Input impedance	1 M $\Omega$ $\pm 5\%$ within 35 pF	
Input terminal	3/4" Binding-post	
Maximum allowable input voltage	600 Vp-p <i>Less than 1min</i>	DC + ACp-p AC: Less than 1kHz
Direct CRT terminal	Sensitivity : 10 V/DIV or over	

### EXTERNAL HORIZONTAL AMPLIFIER

Characteristic	Specification	Remarks
Sensitivity	250 mV/DIV or over	1 DIV 6 mm
Frequency bandwidth	DC ~ 500 kHz	within - 3 dB
Input impedance	1 M $\Omega$ $\pm 10\%$ within 35 pF	
Input terminal	Binding-post	
Variable range	.1 ~ 1/10 or more	
Maximum allowable input voltage	100 Vp-p <i>Less than 1min</i>	DC + ACp-p AC: Less than 1kHz

538

### TIME BASE

Characteristic	Specification	Remarks
Sweep frequency	10 Hz ~ 100 kHz	
Synchronizing	Internal only	

### Z AXIS

Characteristic	Specification	Remarks
Sensitivity	Approx. 25 Vp-p	

### CRT

Characteristic	Specification	Remarks
Type	75 mm round screen CRT	

### POWER REQUIREMENTS

Characteristic	Specification	Remarks
Voltage	100V, 110V, 117V 220V, 230V, 240V	Selected by change of internal connection
Frequency	50 ~ 60 Hz	
Wattage	Approx. 10 VA	

### DIMENSIONS AND WEIGHT



Characteristic	Specification	Remarks
Dimensions	202mm W x 160mm H x 305mm D	Overall
Weight	Approx. 3.5 kg	

### ACCESSARIES

Instruction Manual .....1

### 3. EXPLANATION OF PANEL ( Fig. 1 and 2 )

#### Front Panel

1	POWER ON OFF	Power on and off switch.
2	 POSITION	Horizontal positioning of the spot ( or trace ) on the CRT screen.
3	 POSITION	Vertical positioning of the spot ( or trace ) on the CRT screen.
4	VERT GAIN VARIABLE	Continuously-variable control of vertical deflection sensitivity.
5	VERT GAIN	Vertical deflection sensitivity in 3 steps. The sensitivity is maximum ( unity ) when 1/1 range. It is reduced by a factor of 1/10 or 1/100 range respectively. GND : Input signal is removed and the input circuit is grounded. Does not ground the input signal.
6	AC DC	This selects the method of coupling signal to the input of the vertical amplifier. AC : Signal is capacitively coupled to the vertical amplifier. DC component of signal is blocked. DC : All components of the input signal are passed to the vertical amplifier.
7	VERT INPUT	Input terminal for vertical deflection of trace.
8	GND	Ground terminal.
9	EXT HORIZ IN	External signal input terminal for horizontal deflection.
10	SWEEP RANGE	This selects sweep frequency in 4 steps. When this knob is turned to the extremely clockwise position ( EXT HOR position ), the input signal for horizontal amplifier is connected to the EXT HORIZ IN terminal to operate in the external sweep mode.

11	HORIZ GAIN	For continuously-variable control of horizontal deflection sensitivity.
12	SWEEP VARIABLE	For continuously-variable control of time axis sweep frequency.

Rear Panel

13	INTENSITY	CRT intensity ( brightness ) control. The spot ( trace ) becomes brighter as the knob is turned clockwise.
14	FOCUS	For CRT spot ( trace ) focusing.
15	NORM	This selects vertical deflection circuit. The NORM position is for application of the vertical amplifier output to the CRT. The DIRECT position is for application of the external signal ( connected to the direct input terminal ) to the vertical deflection plates through capacitors.
16	INTENSITY MODULATION	Brightness modulation terminal. A negative signal of approximately 25Vp-p is required to cut off the beam from normal intensity.
17	GND	Ground terminal.
18	VERTICAL	Direct input terminals for CRT vertical deflection plates.
19	Cord	Power supply cord.

Bottom

20	DC-BAL	This control should be so adjusted ( with a screw-driver ) that the baseline of trace is not vertically shifted when the VERT GAIN VARIABLE knob is turned.
----	--------	---

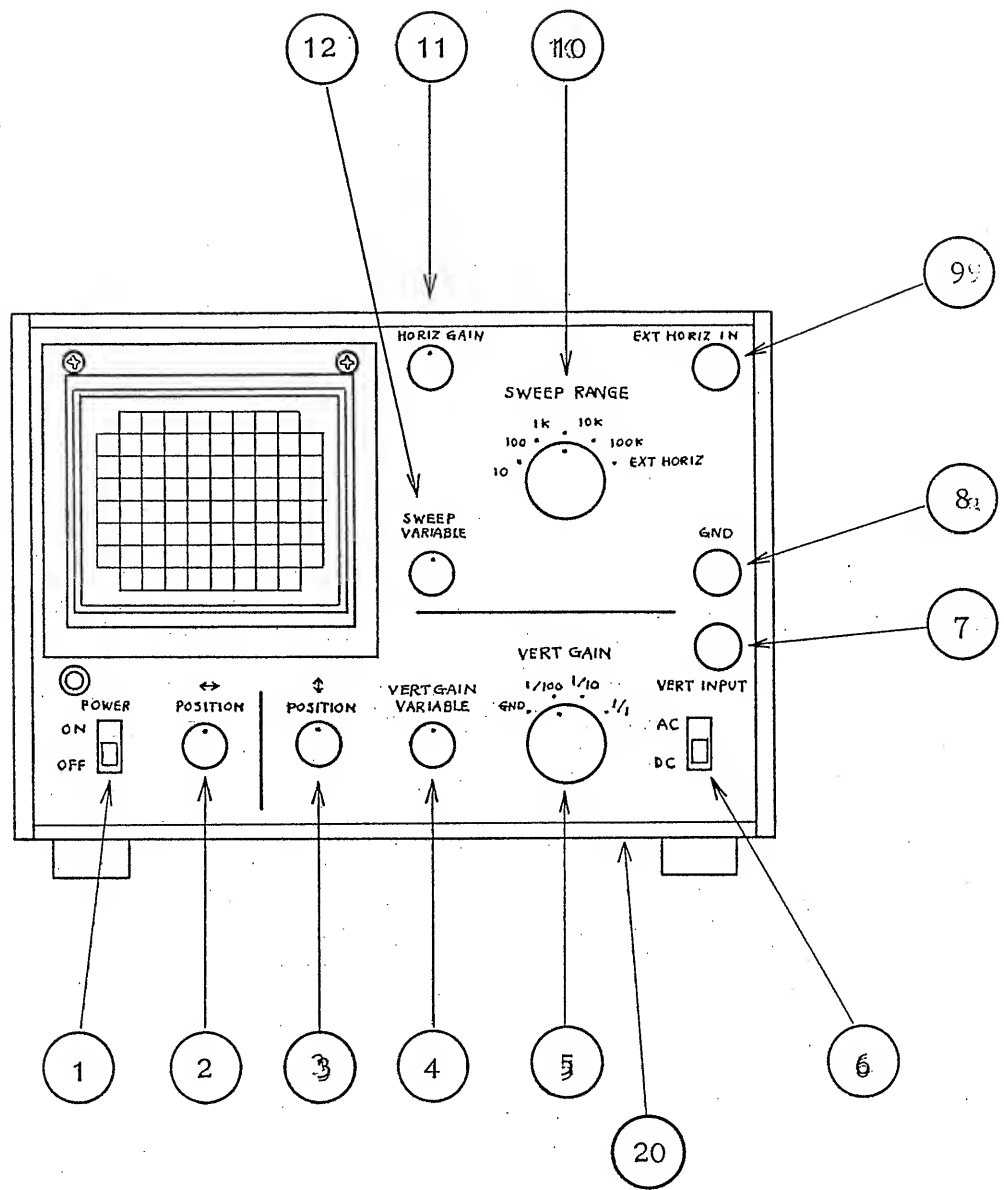

Fig. 1

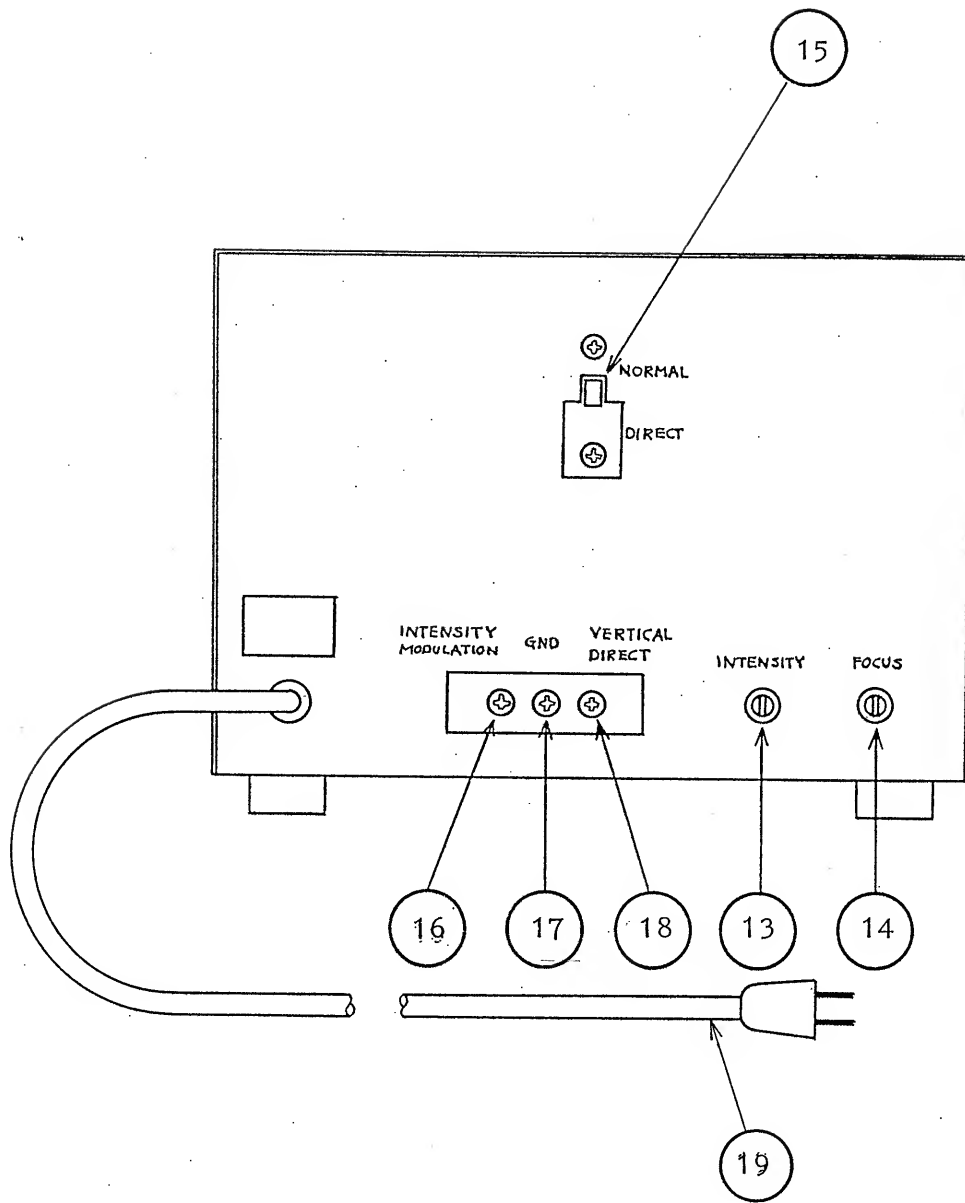

Fig. 2



Therefore the oscillator frequency has been changed to a 100 - 1000 Hz range, set the SWEEP RANGE knob to 100Hz~1kHz, and synchronize the frequency by adjusting the SWEEP RANGE VARIABLE knob.

As the oscillator output voltage increases, the waveform being displayed will spread vertically out of the CRT screen.

In such a case, adjust the waveform to a proper amplitude by means of the VERT GAIN switch and the VERT GAIN VARIABLE knob.

Note : The VERT GAIN VARIABLE knob is capable of adjusting sensitivity continuously from about 1/10 to maximum.

#### 4 - 2 Application

##### (1) Measurement of the frequency response of the amplifier

The measurable part of the audio amplifier are the input terminal and the output terminal to the speaker, because it is difficult for the capacitance of the shielded wire to the input terminal to the oscilloscope. Generally, the output terminal to the speaker is affected little, for the impedance of the output terminal to the speaker is fully lower than the impedance of the shielded wire. ( See Fig. 4 )

Connect the VERT IN terminal (7) and (8) to the output terminal to the speaker and the sine-wave from the audio frequency generator to the AUX terminal. Keep the amplitude of the sine-wave and change the frequency through its range.

The frequency response at each frequency is represented as the amplitude on the CRT screen. ( See Fig. 4 )

##### (2) Monitor of output signal of stereo amplifier ( See Fig. 5 )

1. Set the SWEEP RANGE switch (10) of the oscilloscope to the EXT HORIZ terminal.
2. Set the HORIZ GAIN control (11) to the approximate center through its range.
3. Set the VERT GAIN switch (5) to 1/100.
4. Set the VERT VARIABLE control (4) to the fully clockwise.

5. Connect the LEFT + terminal to the speaker of the stereo amplifier to the VERT IN terminal (7) of the oscilloscope and the LEFT - terminal to the speaker to the VERT IN terminal (8) with the shielded wire.
6. Connect the RIGHT + terminal to the speaker to the EXT HORIZ IN terminal (9) with the shielded wire.
7. Operate the stereo amplifier.  
Lissajous pattern by the left and right signal of the stereo amplifier is represented on the CRT screen.
8. Adjust the amplitude with the control (4) and (10), and set the position of the figure on the CRT screen to the center with the control (2) and (3).

(3) Application of vertical direct deflection terminal

Use the direct deflection terminal for the signal with 1.5 MHz or more. Direct deflection means the deflection by the signal which is directly coupled to the deflection plate without the vertical amplifier. Therefore, the signal with 10Vp-p or more is necessary.

1. Switch the NORM-DIRECT switch (15) on the rear panel to the DIRECT for the direct deflection.
2. Connect the signal to the VERTICAL DIRECT input terminal (18) and GND terminal (17).
3. The position of the waveform on the CRT screen is moved by the POSITION control (2) and (3) on the front panel.

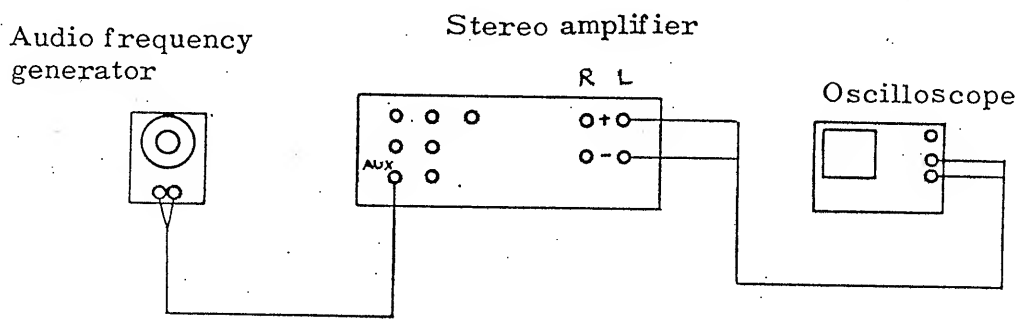
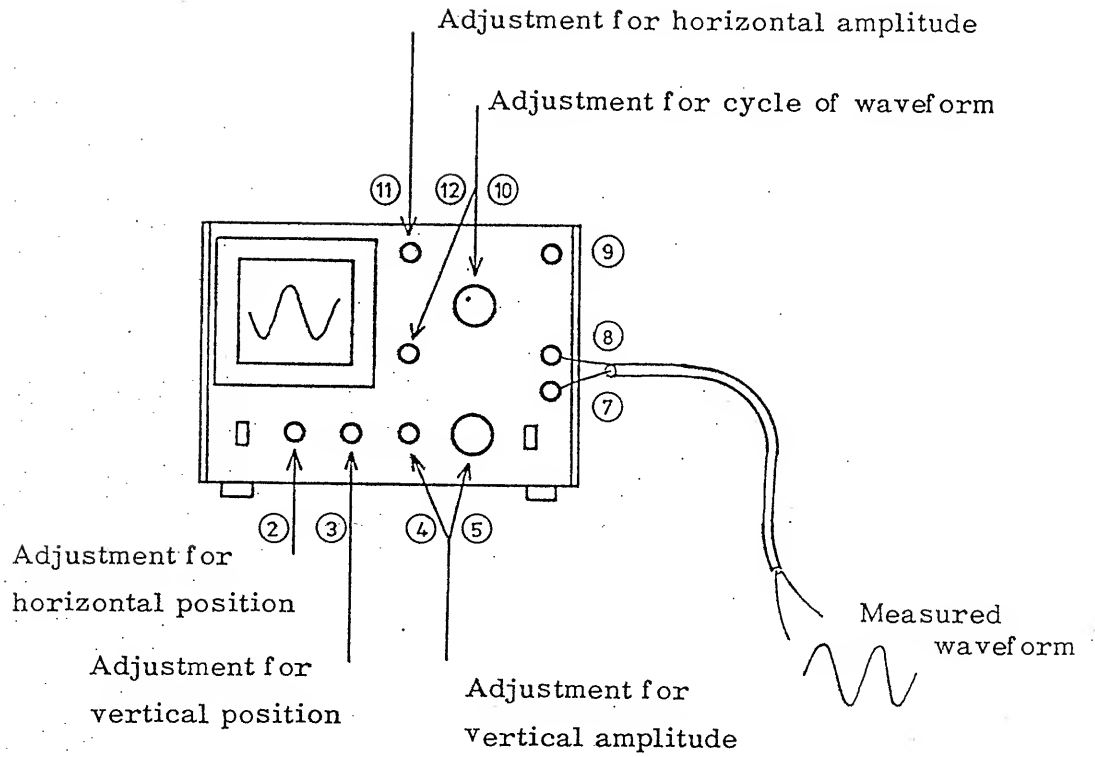

Fig. 4

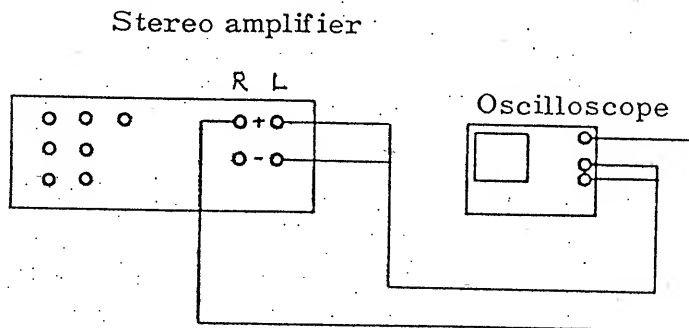

Fig. 5

## 5. CAUTION ON OPERATION

### 5 - 1 Supply Line Voltage ( See Fig. 8 )

This instrument can be operated safely under the fluctuating range of the rated voltage within 10% in the printed supply line voltage on the rear panel. Change the wiring of the transformer when operating at the voltage over the range of the rated voltage.

See ' Change of Supply Line Voltage ' for changing of wiring of the transformer.

### 5 - 2 Fuse

0.5A is used for a nominal 100V ~ 117V supply line voltage. 0.2A is used for a nominal 220V ~ 240V supply line voltage.

See ' Exchange of Fuse ' for exchanging the fuse.

### 5 - 3 Ambient Temperature

Do not expose to direct sunlight and do not put on the amplifier or the other instrument generating heat.

Operate at the range of 5°C ~ 35°C of the ambient temperature.

The specifications may not be satisfied and the life may be shorten, when operating over the appointive ambient temperature.

### 5 - 4 Maximum Input Voltage

Maximum allowable input voltage is specified so that the input voltage exceed the withstand voltage of electronic parts using for this instrument.

Do not apply excessive voltage over the rated voltage to the input terminal for protecting the parts from the damage.

VERT INPUT terminal (7)                      Maximum    \*600Vp-p  
EXT HORIZ IN terminal (9)                    Maximum    \*100Vp-p

\* AC : Less than 1 kHz, Less than 1 min.

5 - 5 Life of the CRT

The life of the CRT will be shorten if the trace should be brighten, the spot should be kept or the supply line voltage should be kept excessive high for a long time.

5 - 6 Maximum Input Voltage to EXT HORIZ IN Terminal without Distortion of Waveform

The horizontal axis of this instrument is designed by taking serious view of phase. For this purpose, the source follower is used for the impedance convertor between the HORIZ GAIN control and EXT HORIZ IN terminal. The dynamic range of the horizontal amplifier is a little narrow for above reason. The waveform is saturated for approximately 8Vp-p or more input.

532. 2500

## 6. MAINTENANCE AND CALIBRATION

### 6 - 1 Case Removal ( See Fig. 7 )

- (1) Remove the six screws on the side of the case and the two screws on the upper part of the case.
- (2) Slide approximately 2 cm the case to the rear and remove the case.
- (3) The panel for the check on the bottom is removed by three screws.

### 6 - 2 Change of Supply Line Voltage ( See Fig. 8 )

- (1) Disconnect the instrument from the source when changing a supply line voltage.
- (2) Change the wiring of the transformer to match the power source. Caution the relation between the color of the wire and the supply voltage.

### 6 - 3 Exchange of the Fuse ( See Fig. 8 )

- (1) The fuse is located on the printed circuit board in the case. 0.5A is used for a 100V ~ 117V nominal line voltage and 0.2A is used for a 220V ~ 240V nominal line voltage.  
Change the fuse after the repair of the cause when a fuse is broken.

### 6 - 4 Adjustment of DC Balance ( See Fig. 9 )

The horizontal trace may shift when rotating the VERT VARIABLE control

(4). Adjust the DC BAL control (20) as shown below for no baseline shift of a CRT display.

- (1) Set the VERT GAIN switch to GND.
- (2) Position the trace to the center horizontal graticule line with the VERT POSITION control.
- (3) Rotate the VERT VARIABLE control through its range.  
Adjust the DC BAL control (20) for no trace shift on the CRT screen.

6 - 5 Frequency Compensation for VERT GAIN Switch ( See Fig. 9 )

- (1) A 1 kHz square-wave with  $0.1\mu\text{s}$  or less and without overshoot is required for the adjustment.
  - (2) Set the VERT GAIN switch to 1/10 and adjust the square-wave amplitude for a four division display.
  - (3) Adjust the semi-fixed capacitor (21) in Fig. 6 for the correct waveform.
  - (4) Set the VERT GAIN switch (5) to 1/100 and adjust the square-wave amplitude for a four division display.
- Repeat the adjustment of procedure (3).

Incorrect

Correct

Incorrect

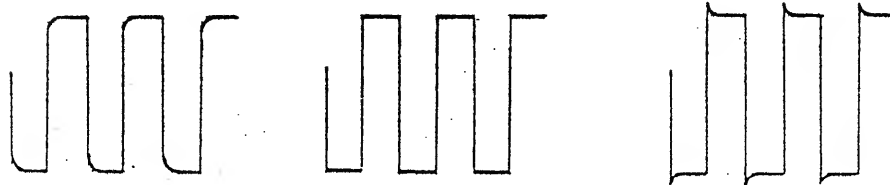

Fig. 6

6-6 Adjustment of high frequency response compensation of the Vertical Amplifier. ( See Fig. 9 )

This adjustment is the phase compensation of the vertical amplifier at high frequency. It is necessary to use a 100 kHz square-wave with 1 ns or less risetime for this adjustment. Such a square-wave generator is a special instrument. This procedure is only method for the adjustment of the high frequency response compensation. Do not adjust the compensator without the appointive square-wave generator.

- (1) Set the VERT GAIN switch to 1/1.

- (2) Connect a 100 kHz square-wave with 1 ns or less risetime to the VERT INPUT terminal between (7) and (8).
- (3) Adjust the SWEEP RANGE switch (10) and the SWEEP VARIABLE control (11) for 2 or 3 cycles on the CRT screen.
- (4) Turn the VERT VARIABLE control fully clockwise, for the rising part of the waveform is changed a little when rotating the VERT VARIABLE control (4).  
Adjust the control (23) for minimum of the overshoot and the undershoot.

#### 6 - 7 Adjustment of Horizontal DC Balance ( See Fig. 9 )

This is the adjustment of the DC balance of the horizontal amplifier.

- (1) Set the SWEEP RANGE switch (10) to EXT.
- (2) Adjust the control (24) so that the spot on the CRT screen does not move when rotating the HOR GAIN control through its range.

#### 6 - 8 Adjustment of Trace Alignment ( See Fig. 10 )

The trace may not be parallel to the horizontal graticule line, for the CRT beam is reflected by terrestrial magnetism. In such a case, remove the case and rotate the CRT so that the trace is parallel to the horizontal graticule line.

- (1) Loosen the CRT clamping screw and rotating the CRT by holding the body of the CRT.

Do not rotate by holding the socket of the CRT.

5-78, 95-000

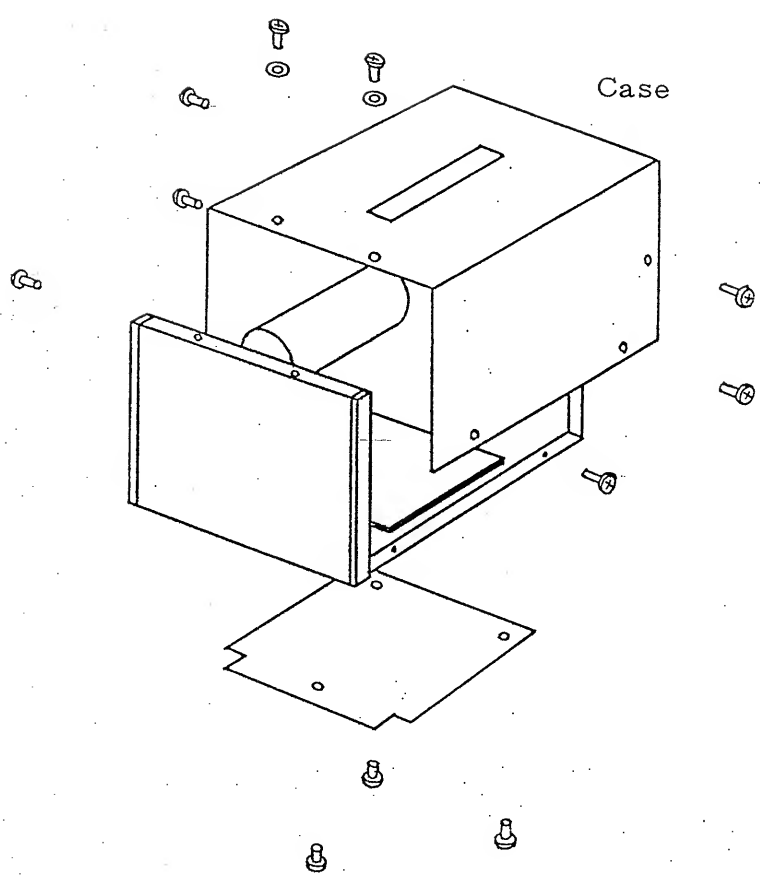
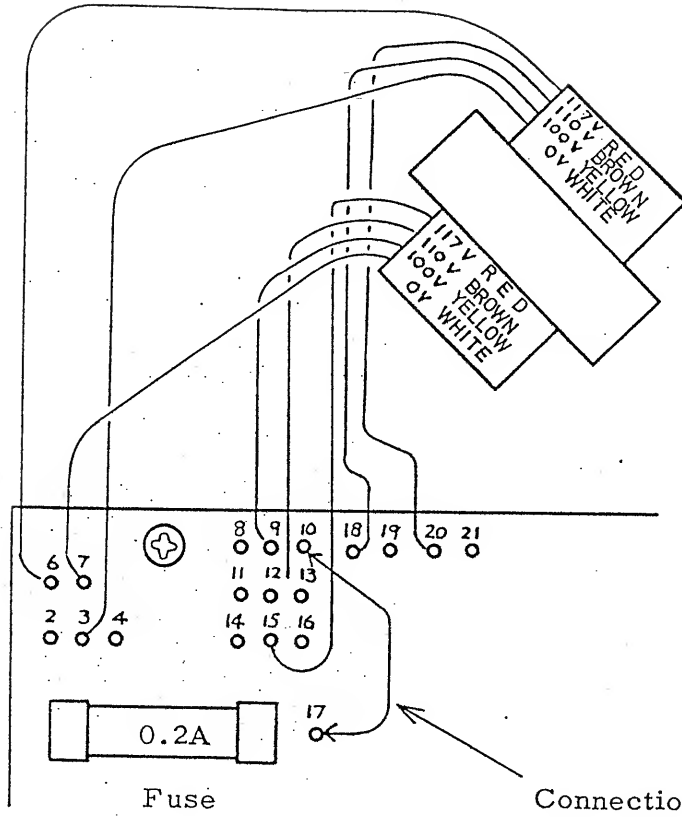

Fig. 7

Connection for 220 V



Voltage	Connected terminal
240 V	17 and 16
230 V	17 and 13
220 V	17 and 10

- 117 V red wire
- 110 V brown wire
- 100 V yellow wire
- 0 V white wire

Connection for 100 V

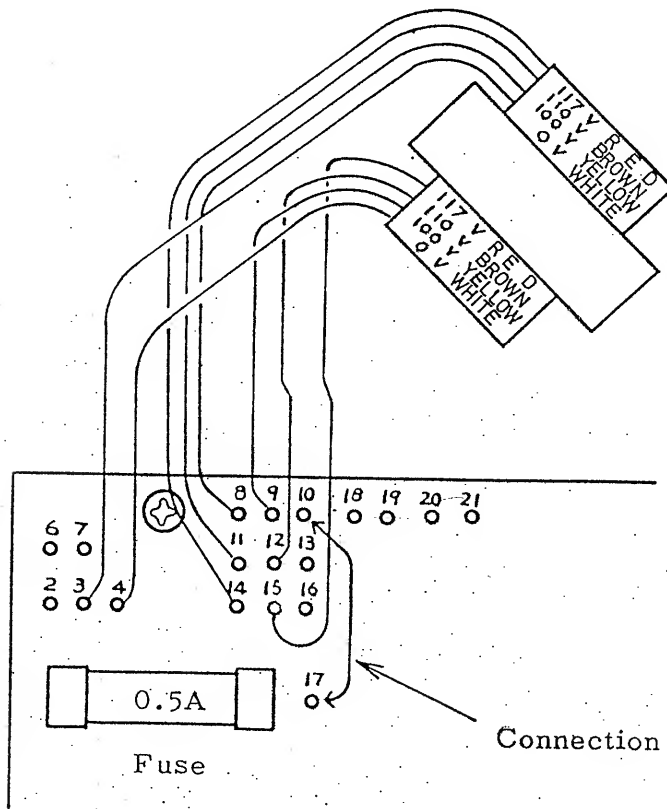

Voltage	Connected terminal
117 V	17 and 16
110 V	17 and 13
100 V	17 and 10

- 117 V red wire
- 110 V brown wire
- 100 V yellow wire
- 0 V white wire

Fig. 8

Top View

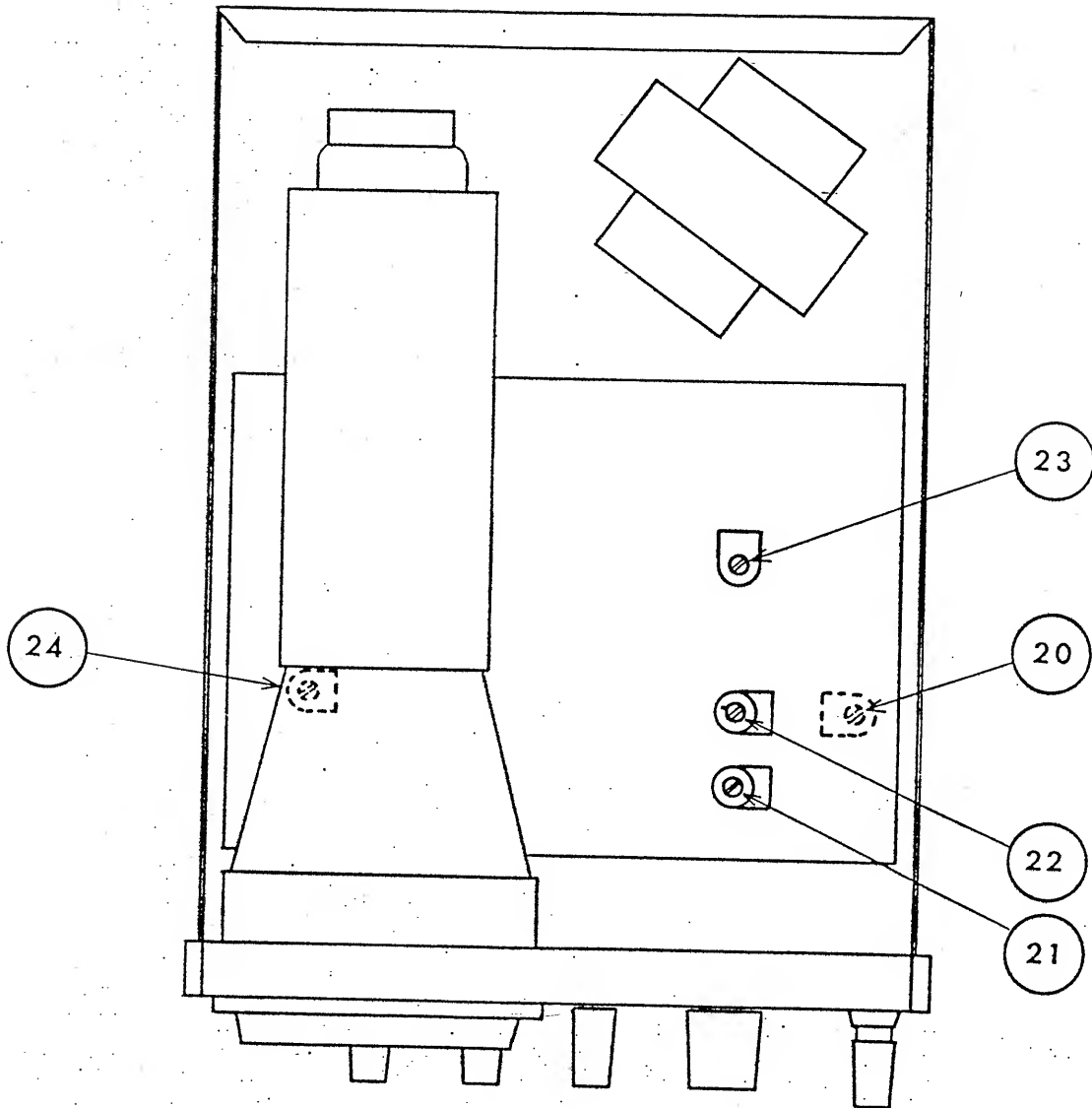

Fig. 9

5-28-7500

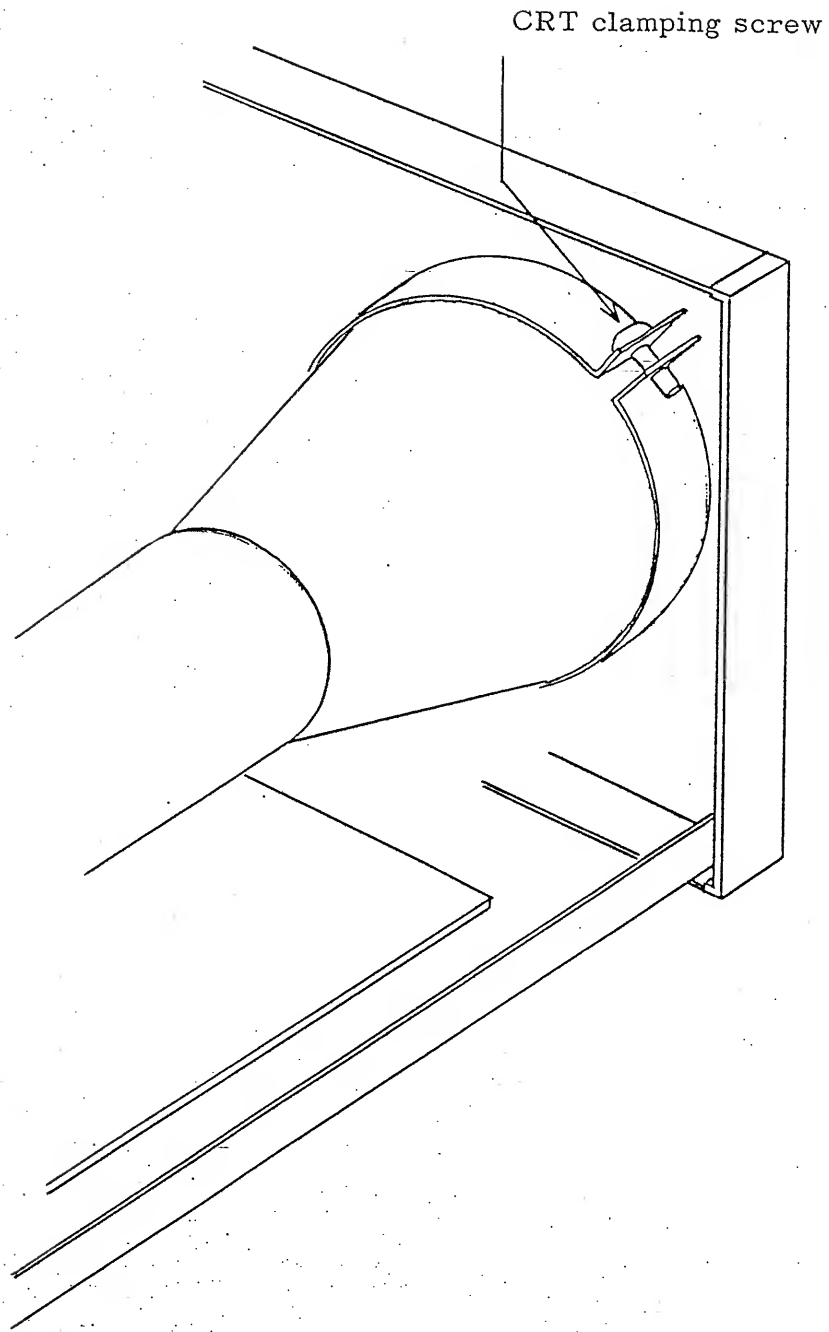

Fig. 10

138. 2500